

Typ / Type : RS 150		Art.-Nr. / Art.-No. : F00-15050	
U	230V (50Hz)	Δp _{fa} min	-- Pa
P ₁	0,07 kW	ΔI	-- %
I _N	0.30 A	I _A / I _N	1.5
n	2400 min-1		IP44
C _{400V}	2 μF		01.009
t _R	70 °C		3.0 kg

Geräusche / Sound levels:

LWA _{rel} A-bewertet bei V=0,5*V _{max} LWA _{rel} A-weighted at V=0,5*V _{max}	fM [Hz]						
	125	250	500	1K	2K	4K	8K
LWA2 [dB(A)] Gehäuse / casing	33	40	43	43	44	32	23
LWA5 [dB(A)] Ansaugseite / inlet side	40	54	55	55	54	50	41
LWA6 [dB(A)] Ausblasseite / outlet side	37	49	47	51	52	49	39

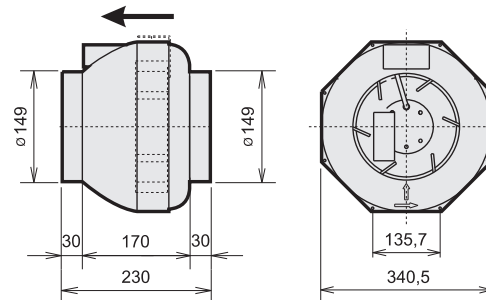

Maße / Dimensions:

(alle Maße in mm / all dimensions in mm)

Schaltbild / Wiring diagram: